

Model ACPO

- Band II
- FM Band 87.5÷108 MHz
- Tuned Antenna
- True Circular Polarization
- Stainless Steel AISI 304

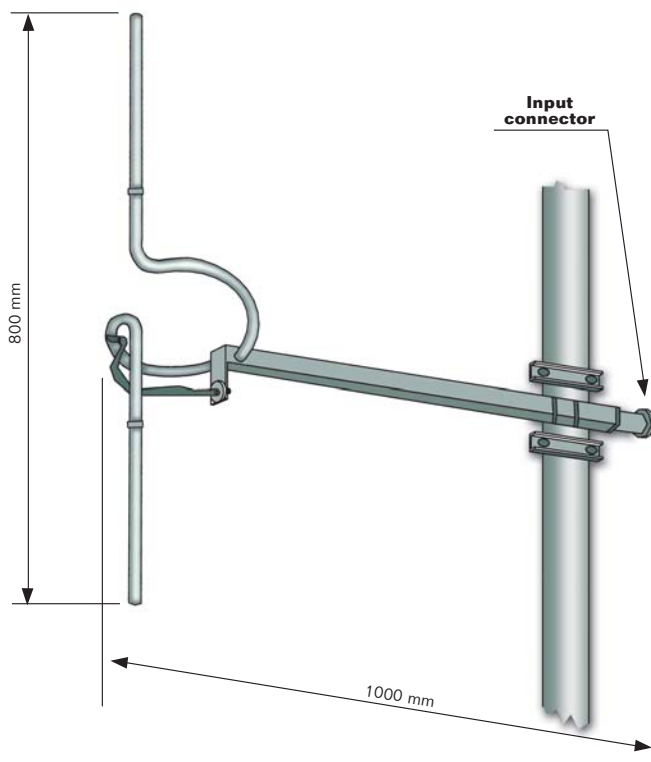

ELECTRICAL DATA

Frequency range	87.5+108 MHz
Impedance	50 Ohm
Connectors	N female
Max Power	800W (N female)
VSWR	≤ 1.1:1
Polarization	Right circular
Gain	-3.4 dB
Pattern	Omni directional ± 1.5 dB in free space Omni directional ± 3 dB with 100mm dia. pole
Lightning protection	All metal parts DC grounded

MECHANICAL DATA

Dimensions	1000 x 300 x 800 mm
Net Weight	3.0 Kg without clamp 5.5 Kg with clamp
Wind surface	0.036 m ²
Wind load	6.0 kg (wind speed at 160 km/h)
Max wind velocity	220 km/h
Materials	External parts: stainless steel Internal parts: silver plated brass
Mounting	With special pipe clamps 50+110 mm dia.

RADIATION PATTERN (MID BAND)

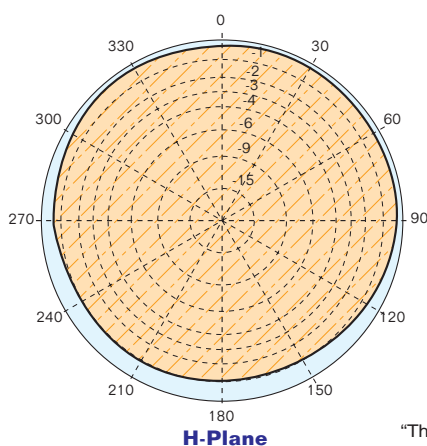

"These specifications are subject to change without notice"

Model ACP0

Radiations systems with ACP0 antenna

Collinears systems

ELECTRICAL DATA	
Frequency range	87.5+108 MHz
Impedance	50 Ohm
Connector	N female
VSWR	≤ 1.1:1 in the operating channel
Polarization	Circular
Gain	Refer to table
Horizontal pattern	Any type according to requirements
Vertical pattern	Null fill, beam tilt and special requirements to order
Other facilities	The antenna system can be supplied in split feed with two equal half antennas. Each half can accept full power

MECHANICAL DATA	
Height of array	Subject to number of bays (refer to table)
Total net weight	According to the working frequency
Wind load	Refer to table (at 98 MHz)
Pressurizable	No
Mounting hardware	Hot dip galvanized steel clamps (option)
Shipping	As required

TECHNICAL DATA

Number of bays	Dipole per bay	Gain ¹		Weight ² kg	Antenna height L m	Wind load (v=160 km/h) kg	Pipe Length m	Tower space m	COLLINEARS SYSTEMS ³				
		dB	times						800 W	1 KW	2 KW	3 KW	5 KW
1	1	-3,4	0.46	5.5	1.4	6	3.1	10	ACP0	-	-	-	-
2	1	-0.0	0.99	11.0	4.0	12	6.1	20	-	ACP0X21	-	-	-
3	1	1.9	1.55	16.5	9.2	18	9.1	30	-	-	-	-	-
4	1	3.2	2.12	22.0	14.4	24	12.2	40	ACP0X41	-	ACP0X42	ACP0X43	-
5	1	4.3	2.70	27.5	19.6	30	15.2	50	-	-	-	-	-
6	1	5.2	3.28	33.0	9.2	36	18.3	60	ACP0X61	-	ACP0X62	ACP0X63	-
8	1	6.5	4.40	44.0	14.4	48	24.4	80	ACP0X81	-	ACP0X82	-	ACP0X85
12	1	8.4	6.85	66.0	19.6	72	36.6	120	-	-	-	-	-

¹ Referred to a half wave dipole. Attenuation of connecting cables not taken into account.

² Without mounting hardware.

³ The systems comprised: antennas, cables and splitter – for more details to see catalog – different version on request.

- Gain is provided for vertical polarization.
- When antenna is pole mounted on the top a tower the horizontally polarized radiation pattern is omni - directional.
- If the antenna is side mounted, the supporting structure will have a slight effect on the radiation pattern and VSWR.
- Vertical tower space, wind load and weight numbers given are typical. Actual values vary with the specific installation. Contact us for more details of your installation.
- Gain will be reduced if null fill, beam tilt or special wavelength spacing is provided.
- Antenna radiation aperture is the distance from the centre of the top bay to the centre of the bottom bay.
- Five ft(1.6mt) of pipe required above the top bay and below the bottom bay for to protect from pattern interference by other antennas.
- Antenna wind load is calculated for 100 Mph (160Km/h) per EIA-222-C standard.

"These specifications are subject to change without notice"

